

INTUWORX NSA52

Penta-Source Media Player / Receiver / Tuner

RevA

Welcome

Thank you for choosing INTUSONIC for your sound system. To make sure that this product meets your expectations and provides long-term, reliable performance, please read and follow this instruction manual carefully.

Manual language

- UK** This user manual is written in English. For other languages, please use an auto-translation service of your choice.
- FR** Ce guide est écrit en anglais. Pour les autres langues, veuillez utiliser un service de traduction automatique de votre choix.
- DE** Diese Anleitung ist in Englisch verfasst. Für andere Sprachen verwenden Sie bitte einen automatischen Übersetzungsdienst Ihrer Wahl.
- ES** Este manual está escrito en Inglés. Para otros idiomas, utilice un servicio de traducción automática de su elección.
- PT** Este manual está escrito em Inglês. Para outros idiomas, use um serviço de tradução automática de sua escolha.
- IT** Questo manuale è scritto in inglese. Per altre lingue, utilizza un servizio di traduzione automatica a tua scelta.

Important safety instructions

- Read these instructions and all markings on the product. Keep these instructions.
- Heed all warnings and instructions, both in this manual and on the product.
- Clean only with a dry cloth. Unplug the unit or its power adaptor/charger from AC supply before cleaning.
- Do not use this product near water and avoid any exposure to water.
- Before connecting this product to any AC supply (if any), make sure to check whether the AC mains voltage and frequency match the indication on the product and its packaging.
- Only connect this product or its power adaptor/charger to an AC supply (if any) with sufficient power handling, protective earth connection, ground-fault (earth-fault) protection and overload protection.

- Disconnect the product or its power adaptor/charger from the AC supply (if any) during thunderstorms or longer periods of being unused.
- Make sure any heat sink or other cooling surface, or any air convection slot, is exposed sufficiently to free air circulation and is not blocked.
- Do not operate this product in environmental temperatures exceeding 35 degrees Celsius and/or 85% relative humidity.
- Position the product in a safe and stable place for operation, out of reach of unauthorized persons.
- Make sure any cable connections to and from the product are neither subject to potentially destructive mechanical impact nor present any risk of stumbling or other accident risk to people.
- Audio equipment may generate sound pressure levels sufficient to cause permanent hearing damage to persons. Always start up at low volume settings and avoid prolonged exposure to sound pressure levels exceeding 90dB.
- Do not open this product for service purposes. There are no user-serviceable parts inside.
- Warranty will be void in any case of unauthorized service by the user or other not authorized persons.
- Take any precaution required by local law, applicable regulations or good business practice to avoid injury of people or material damage by use of this product.

Symbols used in this manual



DANGER! Safety hazard. Risk of injury or death.



ATTENTION! Read manual before installation and operation.



WARNING! Hazardous voltage. Risk of severe or fatal electric shock.



WARNING! Fire hazard.

Health Advice

This unit may produce and absorb electromagnetic radiation. The strength of radiation and the sensitivity for disturbing interference matches the CE and FCC requirements. A corresponding sign is printed on the backside of the unit. Any change or modification may affect the behavior of the unit

concerning electromagnetic radiation, with the CE and FCC requirements eventually not to be met any more. The manufacturer takes no responsibility in this case.

Functional Advice (only for powered products)

This unit is immune to the presence of electromagnetic disturbances – both conducted and radiated - up to a certain level. Under peak conditions, the unit is classified to show a “class C” performance criteria and may encounter temporary degradation or loss of function which may need manual help to recover. In such case, switch the unit off and back on to recover.

Environmental Advice

This unit is built to conform to the ROHS-2 standard according to directive 2011/65/EU and the WEEE directive 2012/19/EU of the European Parliament and of the Council of the European Union. Under these regulations, the product shall not be discarded into regular garbage at the end of its life, but shall be returned to authorized recycling stations.

Battery Advice (only for battery-powered products)

- Some products may contain a battery. Refer to the further chapters of this manual to determine whether this product contains a battery, and whether this is removable and/or rechargeable.
- Where applicable, adhere to the relative regulations in aviation transport.
- If the battery is rechargeable, the battery might not be fully charged or partly discharged at the time of purchase. Recharge before use. Only use recommended or included chargers with appropriate voltage/current rating.



WARNING! Fire hazard. Batteries might heat up during charging. Only charge in a place with sufficient air convection.

Wireless Advice

- Some products may contain a wireless transmitter, receiver or transceiver. Refer to the further chapters of this manual to determine whether this product contains a wireless function, and in which frequency this operates.

- Make sure the frequency of operation does not require a specific license in the territory you operate the product in. If it does, obtain such license prior to any operation.
- Certain wireless technologies are designed for short distance operation. The actual distance will depend on how jammed the frequency band is at the location of use. In adverse cases, operational distances might be as low as 5m. In normal circumstances, 10m can be assumed. Test the operational distance prior to relying on the wireless functionality in a specific application.

Unpacking

Please check that the box contains the following items:

- 1 pc. main unit
- 1 pc. AC cord set
- 1 pc. IRB31 remote control
- 1 pc. instruction manual

If any part is missing, please contact your dealer immediately for replacement.



WARNING! After unpacking, and before plugging the AC cord in the wall outlet, check whether the AC mains voltage and frequency is the same as this product is specified for (see rear panel of product). Whenever the specified voltage or your AC plug should not match the local conditions, do NOT plug the AC cord into the wall outlet and contact your dealer immediately.

AC Mains Voltage Setting

If the AC mains voltage of your power outlet and the setting of the AC supply voltage on your unit do not match, contact your dealer, contractor or a qualified service workshop to change the setting of the AC voltage selector. The AC voltage selector switch is located on the side panel of the unit, close to the AC inlet.

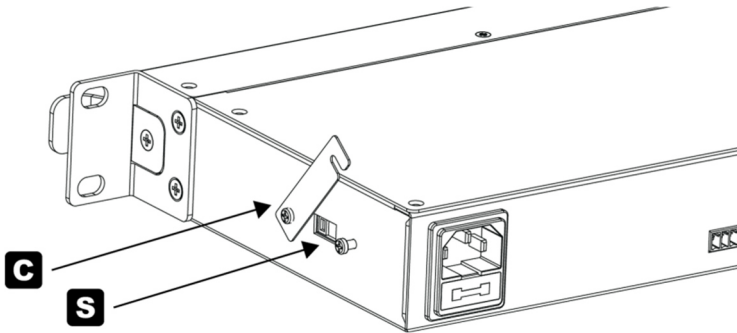

For a qualified technician to change the AC voltage setting, the AC cord shall be detached, the security cover (C) shall be flipped up, and the Voltage selector switch (S) shall be set to the new position. Afterwards, the security cover (C) shall be set back into a protective position to avoid tampering with the switch.

Rack/Cabinet Mounting

This product comes pre-assembled with 19" rack ears and handles. Depending on the location of installation and use, it might be commendable to remove either only the handles, or both the rack ears and handles. To do so, remove the screws at the side panel of the units as shown: To remove the handle (H), remove the single center screw out of the group of 3 screws at the front side of the metal cabinet. Pull the handles out to the front. To also remove the rack ears (E), remove the remaining two screws and then remove the rack ear.

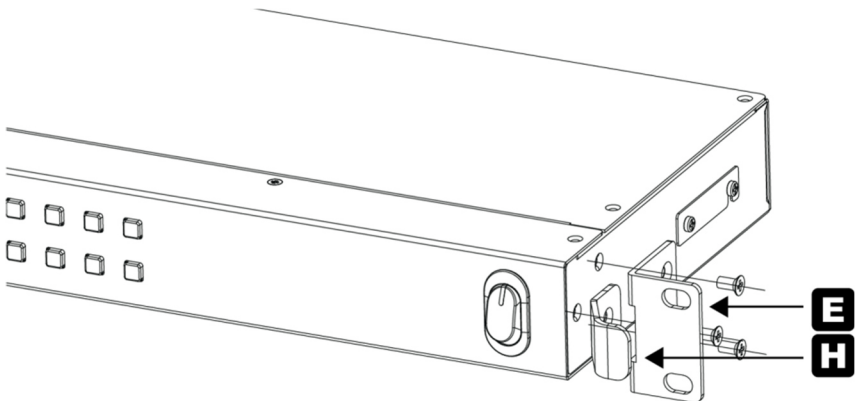

About this product

The NSA52 is an audio media player with 5 sources, including MP3, terrestrial analog radio (FM), terrestrial digital radio (DAB+), Linkoustic™ wireless audio link and a scheduled jingle player. The jingle player offers 4 jingles which can also be externally triggered. Most preferred stations can be stored to 10 station preset keys. Balanced and unbalanced audio outputs and the adjustable volume makes this unit the perfect audio source for many commercial sound systems.

Controls and Connections

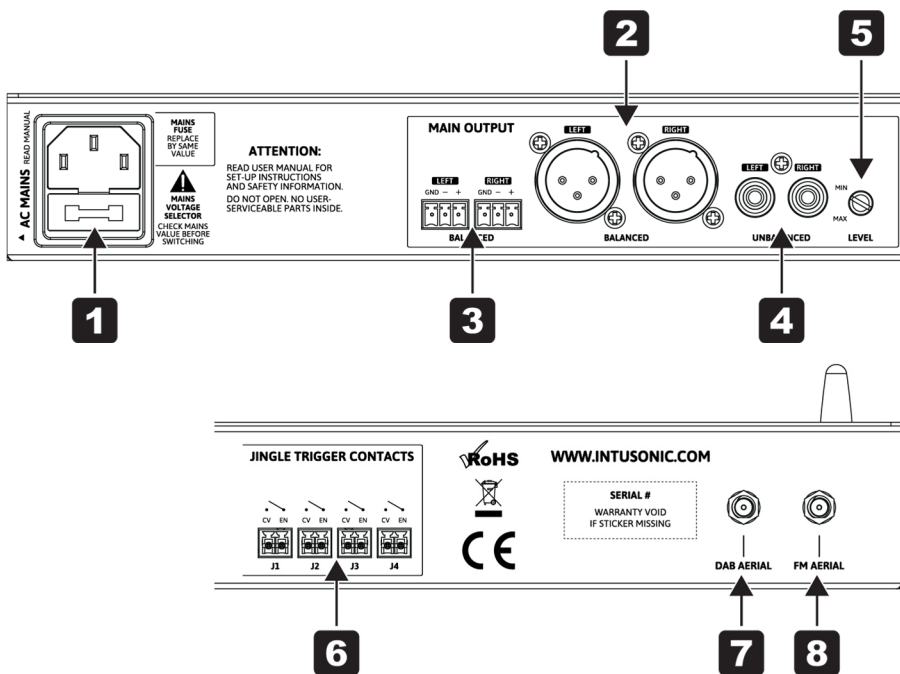

1 AC inlet and fuse holder. Use the supplied AC cord to connect the unit to AC mains. Make sure voltage and frequency stated and set on the unit comply with your local AC supply. The fuse can be accessed by the small drawer at the AC inlet. To change the fuse, unplug the AC cord first, pull out the fuse drawer and replace the fuse ONLY with a fuse of SAME voltage and rating. If the fuse blows again after replacement, hand over the unit to qualified service personnel.

- 2** **Balanced Stereo Main output.** This is a pair of balanced male XLR sockets carrying the main stereo output signal controlled by the level control (5).
- 3** **Balanced Stereo Main output.** This is a balanced dual 3.5mm terminal block output carrying the main stereo output signal (same as 2) controlled by the level control (5).
- 4** **Unbalanced Stereo Main Output.** This is an unbalanced pair of RCA sockets carrying the main stereo output signal (same as 2) controlled by the level control (5). Note that the total angle is 300 degrees; do not apply excessive force with the screwdriver.
- 5** **Output level control.** Allows the adjustment of the output level to match following devices. Adjustments shall be made with a small screwdriver. Note that the total angle is 300 degrees; do not apply excessive force with the screwdriver.
- 6** **External Jingle Trigger contacts.** These are four potential-free contacts to allow remote triggering of the up to four internal jingles (see section “Jingle Player”). An external switch or relay allow to invoke jingle replay. Make sure the external switch does not carry any voltage.
- 7** **Aerial connection for terrestrial digital (DAB+) radio.** Connect a suitable aerial with sufficient exposure to terrestrial radio broadcasting; beware of poor RF signals voiding proper operation.
- 8** **Aerial connection for terrestrial analog (FM) radio.** Connect a suitable aerial with sufficient exposure to terrestrial radio broadcasting; beware of poor RF signals voiding proper operation.

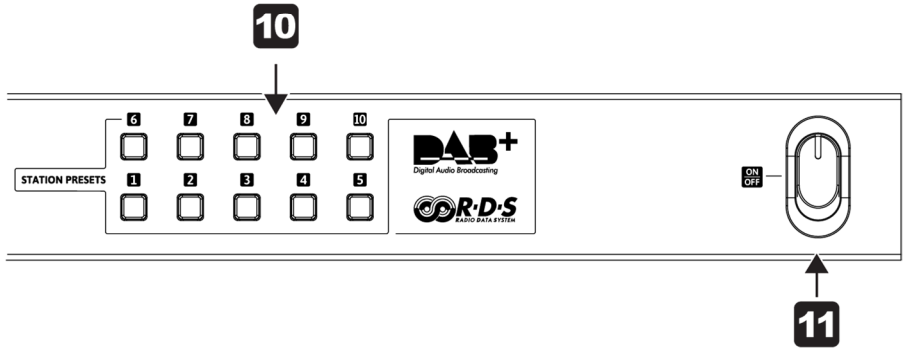
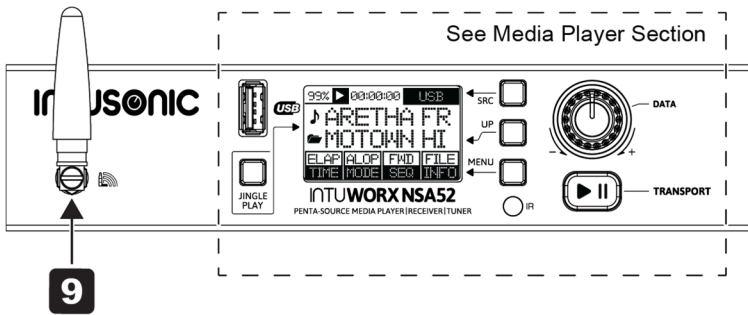

- 9** **Wireless Audio Link antenna.** This is the antenna mounting position for the Linkoustic™ wireless audio link. Mount the supplied antenna here; do not use any other antennas.
 - 10** **Station preset buttons.** These buttons allow direct recall of the stored station presets. They can also be used in the preset programming process instead of the encoder to select a preset.
 - 11** **Power switch.** Switches the unit on and off. Make sure to switch the unit off when not in use. The ON position is indicated by a backlight.
- Media Player**

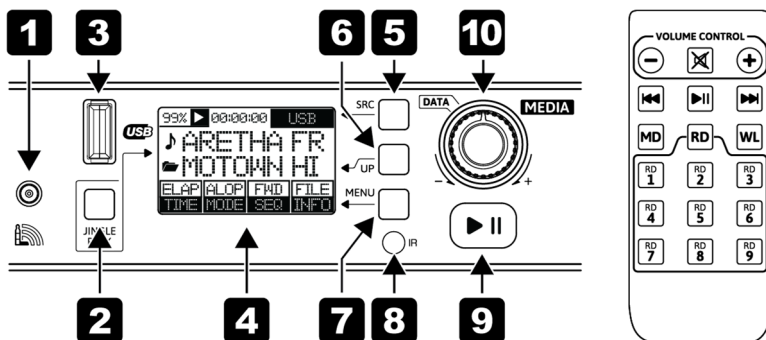

This product is fitted with a multi-source media player. Apart from the front-panel volume controls, the media player can also be controlled via the included IR remote control. The basic operation follows the below concept:

- A source can be selected via repeatedly pressing the SRC button (5). Depending on the country version of the media player, the SRC button will cycle through the following source options: USB – FM Radio – DAB+ Digital Radio – Linkoustic™ Wireless. The source will be active immediately. Alternatively, the source can be selected via the infrared remote control; with the MD (Media) button selecting the USB player, the WL (Wireless) button selecting the Linkoustic™ Wireless link, and the RD (Radio) button selecting the radio receiver. If the unit is fitted with the DAB+ option, repeatedly pressing the RD button on the IR remote control will toggle between the FM and the DAB+ mode.
- Whenever the source is changed via the SRC button (5), the settings for the prior source are stored. Storage of these settings also survives power cycling, and the unit will start up in the source setting it was switched off at.
- The Jingle player can be activated via the JINGLE button (2) and always has priority over any other source. Whatever Jingle player action is activated, the current source will be replaced by the jingle replay, and player will return to the prior source once the jingle replay is done. See “Jingle Player” section for details.
- The lower menu bar section of the display (4) will change its content based on the selected source, see relative chapters for each source. The menu bar items can be toggled through its submenus via the MENU button (7), the current submenu selected for modification of activation will start to flash. Alternatives can be chosen via turning the encoder (10), and the final choice can be

activated via pressing the encoder. It shall be noted that the menu items can only be toggled through via the MENU button (7), not by turning the encoder (10). The encoder only serves for selection of submenu entries and confirmation by pressing. In case there are no selections to be made in a submenu, turning the encoder may be without effect. Confirmation of a menu bar item will exit the menu bar and any new selection requires to start over by pressing the MENU button (7).

- With any selected source, the Play/Pause button will either stop (for USB) or mute (for FM, DAB+ and Wireless) the replay. When the source is playing/unmuted, the Play/Pause button is lit, when the source is paused/muted, the button is flashing. Navigation is unaffected by the Play/Pause status.
- The UP button (6) is assigned to different functionality depending on the chosen source, see relative chapters for each source.
- Any navigation that is not prompted with a confirmation of a selection will be aborted automatically after 5 seconds of non-activity (inactivity timeout), and the player will return to the status prior to the navigation attempt.
- Note that proper operation of the IR remote control requires unobstructed line of sight between the remote control and the IR sensor (8).

SOURCE: USB

- **Display content**

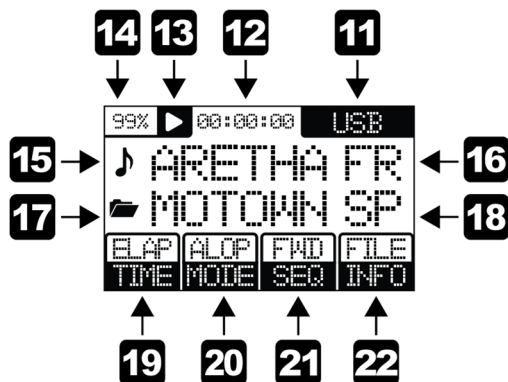

With USB as the selected source, the media player can replay files from an inserted USB flash memory media in a variety of sequence options. The USB media content can be navigated for the next song to be played while a current song is playing.

- 11 Source selection indicator.** Press the SRC button (5) until “USB” is displayed to enable USB replay, or press the “MD” button on the infrared remote control. The content identifier symbol (15) changes to a musical note for indicating a song name, and the root identifier symbol (17) changes to a folder symbol for indicating a folder on the USB media. Note that USB replay can only be enabled if a valid USB media is inserted into the USB port (3). See further notes below on validity of USD media. If no valid USB media is inserted, the display will show “NO FILES” in the content identifier line (16) and “MEDIA” in the root identifier line (18).
- 12 Time counter.** Shows the elapsed or remaining time of the currently playing song, based on the setting made in the time menu (19).
- 13 PLAY/PAUSE indicator.** Shows the current replay status selected by either the Play/Pause button (9) or the relative button on the IR remote control. A triangle indicates PLAY, two parallel vertical lines indicate PAUSE.
- 14 Player output volume.** Indicates the current setting of the player output. This can only be set via the IR remote. After a power cycle, the player will always be reset to full output volume (99%). Note that this setting refers only to the media player – if the media player is built into a host product, the host products volume may not be influence by this.
- 15 Content Identifier Symbol.** This shows what the content identifier line (16) will contain. With USB as the selected source this is a musical note to indicate a song name to be contained in the content

identifier line (16).

16 Content Identifier Line. With USB as the selected source, this shows the song name currently playing or preselected during navigation.

17 Root Identifier Symbol. This shows what the root identifier line (18) will contain. With USB as the selected source this is a folder symbol to indicate a file folder name to be contained in the root identified line (18).

18 Root Identifier Line. With USB as the selected source, this shows the file folder name on the USB media which is currently chosen or preselected during navigation.

19 TIME Choice Submenu. Press the MENU button (7) once to enable the Time Choice menu for editing. The symbol will flash. Turn the encoder (10) to select between

- ELAP (elapsed)
- REM (remaining)

and confirm the choice by pressing the encoder (10). If no choice is made in 5 seconds, the editing process will time out and no changes will be applied.

20 MODE Choice Submenu. Press the MENU button (7) twice to enable the Mode Choice menu for editing. The symbol will flash. Turn the encoder (10) to select between

- 1STP: Single Stop – player will stop after the currently chosen song ended.
- ASTP: All Stop – player will stop after playing all songs in the current folder once; default SEQ (21) setting is FWD (forward).
- 1LOP: Single Loop – player will loop the current song indefinitely.
- ALOP: All Loop – player will loop the songs in the current folder; default SEQ (21) setting is RAN (random).

and confirm the choice by pressing the encoder (10). If no choice is made in 5 seconds, the editing process will time out and no changes will be applied

21 Sequence (SEQ) Choice Submenu. Press the MENU button (7) three times to enable the Sequence Choice menu for editing. The symbol will flash. Turn the encoder (10) to select between

- FWD (forward) – the player plays all songs in the current folder in a straight sequence.
- RAN (random) – the player plays the songs in the current folder in a random sequence.

and confirm the choice by pressing the encoder (10). If no choice is made in 5 seconds, the editing process will time out and no changes will be applied.

Note: The RAN (random) selection is only available for the ALOP setting of the MODE. If RAN (random) was selected in ALOP mode setting, and the MODE is changed to another setting, the SEQ (sequence) will automatically be reset to FWD.

22

INFO Choice Submenu. Press the MENU button (7) four times to enable the Info Choice menu for editing. The symbol will flash. Turn the encoder (10) to select between

- FILE (file name) – the display will show the file name of the currently playing file.
- TAG (tag) – the display will show the MP3 Tag of the currently playing file.

and confirm the choice by pressing the encoder (10). If no choice is made in 5 seconds, the editing process will time out and no changes will be applied.

Note: The player is compatible with ID3V1 tag formats. ID3V23 or ID3V24 tag formats may show undesired results.

■ Navigation Procedure

Notes for navigation in the file/folder system on the USB flash memory media:

- The player supports only one level of folder hierarchy.
- Folders are selected by pressing the UP button (6) first, then turning the encoder (10) to confirm the choice. A direct selection of the next/previous song via turning the encoder is not possible. To facilitate navigation, pressing the UP button will always jump to the folder which contains the currently playing song. However, it is necessary to reconfirm this folder choice again before selecting another song from the same folder.
- Direct next/previous song selection (only inside same folder) is possible via the IR remote control.
- Files not located in a folder will be displayed along the available folders on the top hierarchy level. Once selected, such files will show ROOT as their folder name.
- If no new song choice is confirmed by pressing the encoder (10) is made in between 5 seconds, the navigation process will time out and no changes will be applied.
- Upon insertion of a new media, the user needs may need to press the UP button once first if the media is unknown to the player.

■ Notes for USB media replay:

Notes for the validity of files compatible with this player:

- This player will work with USB flash media up to 64GB of size which is formatted with a FAT12, FAT16, FAT32 or ExFAT file system (FAT32 recommended). The player is not compatible with NTFS-formatted media or any HDDs/SSDs.
- The number of files is not specifically limited, but larger amounts of files will slow down navigation.
- This player will replay files in MP3, WAV, FLAC and APE formats. MP3 files in MPEG 1 Layer 3, MPEG 2 Layer 3, MPEG 2.5 Layer 3 standard are accepted, with sample rates of 128/160/192/224/256/320 kbps + VBR. Any other files existing on the USB flash media will be ignored and are not available for replay.
- File/Folder naming. File or folder names do not have a specific length restriction, but long names will slow down navigation and can cause a lack of comfort in operation, as the display size is restricted and long names will scroll. Keep files names and tag entries short and descriptive for best user experience.
- Folder Sorting. Folders are displayed in the sequence of their creation dates on the solidstate memory media. If a specific sequence is needed, then the folder shall be created in this sequence on the memory media before copying any MP3 files into them.
- File Sorting. Files are displayed in the sequence of their creation dates on the solidstate memory media. If a specific sequence is needed, then the files shall be created/copied in this sequence on the memory media.

SOURCE: FM Radio

- **Display content**

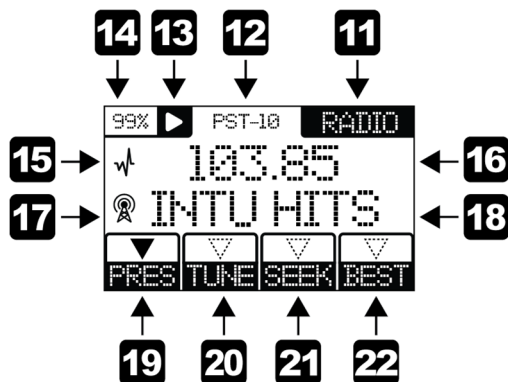

With FM Radio as the selected source, the media player can select and receive FM radio stations. The selection process can be expedited by recalling station memories (presets), manually selecting a tuning frequency or seeking for the next strong station's signal. The station memories (presets) can either be allocated automatically to the 10 strongest stations, or manually by storing a found station to a specific of the 10 preset memories.

Important:

- As with any terrestrially broadcasted service, the quality of reception, and the number of receivable stations and the availability of RDS information will depend on the quality of the signal supplied to the FM antenna socket. A lack of available stations or noisy reception mostly originate from poor antenna signal quality. Make sure to use a properly placed antenna, possibly use an active antenna or a roof-installed shared antenna system.

11 Source selection indicator. Press the SRC button (5) until "RADIO" is displayed to enable FM radio replay, or press the "RD" button on the infrared remote control. If your unit is fitted with the optional DAB+ receiver, the "RD" button may need to be pressed twice as it toggles between the FM and the DAB+ tuner. The content identifier symbol (15) changes to a waveform symbol for indicating a FM station's frequency, and the root identifier symbol (17) changes to an antenna symbol for indicating a radio station's name.

12 Preset Station identifier. Shows the following based on the selected mode submenu (19/20/21/22):

- In PRESET mode - indicated by a solid triangle at the PRESET

selection submenu (19) – this shows the currently active stored station preset. The active preset may be changed by turning the encoder and pressing to activate another preset, or by any of the station buttons on the remote control.

- In TUNE mode - indicated by a solid triangle at the TUNE selection submenu (20) – this shows the word “MANUAL”.

- In SEEK mode - indicated by a solid triangle at the SEEK selection submenu (21) – this shows the word “SEEK”.

- In BEST mode - indicated by a solid triangle at the BEST selection submenu (22), this area is blank.

13 **PLAY/MUTE indicator.** Shows the current replay status selected by either the Play/Pause button (9) or the relative button on the IR remote control. A triangle indicates PLAY, two parallel vertical lines indicate MUTE.

14 **Player output volume.** Indicates the current setting of the player output. This can only be set via the IR remote. After a power cycle, the player will always be reset to full output volume (99%). Note that this setting refers only to the media player – if the media player is built into a host product, the host products volume may not be influenced by this.

15 **Content Identifier Symbol.** This shows what the content identifier line (16) will contain. With FM Radio as the selected source this is a waveform symbol to indicate a station frequency to be contained in the content identifier line (16).

16 **Content Identifier Line.** With FM Radio as the selected source, this shows the frequency of the currently selected radio station.

17 **Root Identifier Symbol.** This shows what the root identifier line (18) will contain. With FM Radio as the selected source this is an antenna symbol to indicate a station name to be contained in the root identified line (18).

18 **Root Identifier Line.** With FM Radio as the selected source, this shows the station name of the currently selected radio station. Please note the display of a station name will only work if the selected station transmits an RDS-compliant station identifier, and if the signal strength/quality is sufficient. In case of insufficient signal quality, it may take significant time to display the station name or the name may remain incomplete, or the line remains blank altogether. If the selected station does not broadcast any RDS identifiers, this line will show “NO RDS”.

19 **PRESET Selection Submenu.** PRESET selection is one of the three station selection options for the FM radio source - the others being TUNE selection (20) or SEEK selection (21). Preset selection calls back one of the previously stored preset memories. Preset selection

will hence only work if sensible stations have been stored in the preset memories beforehand. This can either be done automatically activating the BEST Submenu (22) or by manually storing found stations into preset memories. See more in the “manual preset memory storage” chapter. To activate PRESET selection, press the MENU button (7) once to enable the Preset Selection Submenu for activation. The submenu section will start to flash; press the encoder to activate. The triangle in the submenu section will turn solid once active, and other prior station selection modes will be disabled. If no choice is made in 5 seconds, the editing process will time out and no changes will be applied. Once the PRESET selection is active, the current PRESET is displayed in the Preset Station identifier (12); there are 10 storage memories (PST-1....PST-10). A different PRESET can be activated by turning the encoder (10), the Preset Station identifier (12) will start to flash with the new choice being displayed, while the prior PRESET will keep playing. Press the encoder (10) to confirm the choice, the new PRESET will start playing and the Preset Station identifier (12) will stop to flash. If no choice is made in 5 seconds, the selection process will time out, the Preset Station identifier (12) will stop to flash and no changes to the active PRESET will be applied.

20

TUNE Selection Submenu. TUNE selection is one of the three station selection option for the FM radio source - the others being PRESET selection (19) or SEEK selection (21). TUNE selection allows to manually tune to a certain receiver frequency in 0.05MHz steps. To activate TUNE selection, press the MENU button (7) twice to enable the Tune Selection Submenu for activation. The submenu section will start to flash; press the encoder to activate. The triangle in the submenu section will turn solid once active, the Preset Station identifier (12) will show MANUAL and other prior station selection modes will be disabled. If no choice is made in 5 seconds, the editing process will time out and no changes will be applied. Once activated, you can tune to the desired frequency using the encoder (10). The tuning process is immediate, once the encoder is turned, the new frequency becomes active (no confirmation needed by pressing the encoder).

21

SEEK Selection Submenu. SEEK selection is one of the three station selection option for the FM radio source - the others being PRESET selection (19) or TUNE selection (20). SEEK selection is similar to TUNE selection, but does only offer the next frequency with a sufficiently strong signal for choice upon turning the encoder. To activate SEEK selection, press the MENU button (7) three times to enable the Seek Selection Submenu for activation. The submenu

section will start to flash; press the encoder to activate. The triangle in the submenu section will turn solid once active, the Preset Station identifier (12) will show SEEK and other prior station selection modes will be disabled. If no choice is made in 5 seconds, the editing process will time out and no changes will be applied. Once activated, you can scroll between stations with sufficiently strong signal using the encoder (10). Once turning the encoder, the search for the next strong-enough station start immediately (up or down depending on whether the encoder was turned clockwise or counterclockwise) and will stop at the next station found to have sufficient signal strength. The player will automatically mute during the SEEK process and will un-mute when a sufficiently strong station is found. This station then becomes automatically active.

22

BEST Station Assignment Submenu. This submenu is intended to work in association with the PRESET selection submenu (19), and allows to automatically assign the 10 strongest radio stations to the 10 available memory presets. To expedite this process, press the MENU button (7) four times to enable the BEST station assignment process activation. The submenu section will start to flash; press the encoder to activate. The triangle in the submenu section will turn solid once active, the Preset Station identifier (12) will turn blank, the Root Identifier line (18) will show AUTOSTORE and the unit will be muted during the process. Once finished, the player will automatically select the PRESET Selection Submenu (19), with the first preset active, hence showing PST-1 in the Preset Station identifier (12). It will also un-mute to make the active preset audible. The other presets may now be accessed by turning the encoder (10) and activating the new choice by pressing the encoder, or by the relative buttons on the remote control.

■ Manual Preset Memory Storage Procedure

If using the BEST Station assignment submenu (22) does not deliver the required results, or if specific station presets shall be assigned/overwritten with a new station choice, proceed as follows:

- Activate the TUNE Selection Submenu (20) or the SEEK Selection Submenu (21) and tune to a frequency or station you like.
- Press the UP button (6)**.
- Observe the Preset Station identifier (12) which will now offer a station preset for selection. Turn the encoder (10) until the required station preset is displayed. Press the encoder to confirm.

Alternatively, press any of the ten station preset buttons (see section “Controls and Connections” point 10).

- The chosen station preset is now overwritten with the selected station.
- Change to the PRESET Selection Submenu (19) for direct access to the newly stored station via the encoder (10).

** Note: The UP button is disabled in the PRESET Selection Submenu and BEST Station Assignment Submenu

SOURCE: DAB+ Digital Radio

■ **Display content**

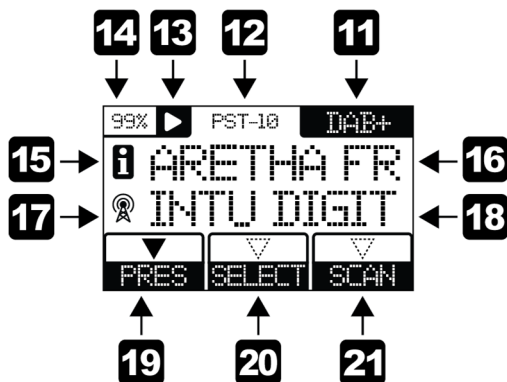

With DAB+ Digital Radio as the selected source, the media player can select and receive digital radio stations following the DAB+ standard. Up to 10 favorite stations can be stored as directly selectable memory presets.

Important:

- The DAB+ feature is optional, since some territories do not offer DAB+ broadcasting services. The below may not apply if your version of this product does not offer the DAB+ feature due to territorial restrictions.
- Due to the nature of digital radio and the channel bundling associated, **the first use of the DAB+ receiver should always commence with a spectrum scan to detect available channels.** Such scan may need to be repeated if the broadcasters change the channel bundling or the station-to-channel assignment. Without prior scan, no channels may be available for replay.
- As with any terrestrially broadcasted service, the quality of reception, and the number of receivable stations will depend on the quality of the signal supplied to the DAB antenna socket. A lack of available stations or interruptions in reception mostly originate from poor antenna signal quality. Make sure to use a properly placed antenna, possibly use an active antenna or a roof-installed shared antenna system.

11 **Source selection indicator.** Press the SRC button (5) until “DAB+” is displayed to enable digital radio replay, or press the “RD” button on the infrared remote control; the “RD” button may need to be pressed twice as it toggles between the FM and the DAB+ tuner. The content

identifier symbol (15) changes to an information symbol for indicating a digital radio station's broadcasted information content, and the root identifier symbol (17) changes to an antenna symbol for indicating a radio station's name.

12 Preset Station identifier. Shows the following based on the selected mode submenu (19/20/21/22):

- In PRESET mode - indicated by a solid triangle at the PRESET selection submenu (19) – this shows the currently active stored station preset. The active preset may be changed by turning the encoder and pressing to activate another preset, or by any of the station buttons on the remote control.

- In SELECT mode - indicated by a solid triangle at the SELECT selection submenu (20) – this shows the word "STATION".

- In SCAN mode - indicated by a solid triangle at the SCAN selection submenu (21) – this shows the word "SCAN".

13 PLAY/MUTE indicator. Shows the current replay status selected by either the Play/Pause button (9) or the relative button on the IR remote control. A triangle indicates PLAY, two parallel vertical lines indicate MUTE.

14 Player output volume. Indicates the current setting of the player output. This can only be set via the IR remote. After a power cycle, the player will always be reset to full output volume (99%). Note that this setting refers only to the media player – if the media player is built into a host product, the host products volume may not be influenced by this.

15 Content Identifier Symbol. This shows what the content identifier line (16) will contain. With DAB+ Digital Radio as the selected source this is an information symbol to indicate a station's broadcasted information content to be contained in the content identifier line (16).

16 Content Identifier Line. With DAB+ Digital Radio as the selected source, this shows the station's broadcasted information content.

17 Root Identifier Symbol. This shows what the root identifier line (18) will contain. With DAB+ Digital Radio as the selected source this is an antenna symbol to indicate a station name to be contained in the root identified line (18).

18 Root Identifier Line. With DAB+ Digital Radio as the selected source, this shows the station name of the currently selected radio station. Note that the station name will be shorted to the available display length.

19 PRESET Selection Submenu. PRESET selection is one of the two station selection options for the DAB+ Digital Radio source - the other being SELECT selection (20). Preset selection calls back one of the previously stored preset memories. Preset selection will hence

only work if sensible stations have been stored in the preset memories beforehand. This can either be done automatically activating the SCAN Submenu (21) or by manually storing found stations into preset memories. See more in the “manual preset memory storage” chapter. To activate PRESET selection, press the MENU button (7) once to enable the Preset Selection Submenu for activation. The submenu section will start to flash; press the encoder to activate. The triangle in the submenu section will turn solid once active, and other prior station selection modes will be disabled. If no choice is made in 5 seconds, the editing process will time out and no changes will be applied. Once the PRESET selection is active, the current PRESET is displayed in the Preset Station identifier (12); there are 10 storage memories (PST-1....PST-10). A different PRESET can be activated by turning the encoder (10), the Preset Station identifier (12) will start to flash with the new choice being displayed, while the prior PRESET will keep playing. Press the encoder (10) to confirm the choice, the new PRESET will start playing and the Preset Station identifier (12) will stop to flash. If no choice is made in 5 seconds, the selection process will time out, the Preset Station identifier (12) will stop to flash and no changes to the active PRESET will be applied.

20

SELECT Selection Submenu. SELECT selection is one of the two station selection options for the DAB+ Digital Radio source - the other being PRESET selection (19). SELECT selection allows to toggle through all stations detected during a spectrum scan (see point 21). Before being able to use the SELECT selection, a SCAN must be expedited at least once first. To activate SELECT selection, press the MENU button (7) twice to enable the Select Selection Submenu for activation. The submenu section will start to flash; press the encoder to activate. The triangle in the submenu section will turn solid once active, the Preset Station identifier (12) will show STATION and other prior station selection modes will be disabled. If no choice is made in 5 seconds, the editing process will time out and no changes will be applied. Once activated, you can scroll between stations (found during the scan) using the encoder (10). Once turning the encoder, the next station is activated immediately.

21

SCAN Activation Submenu. A spectrum scan is a precondition for any stations being available in the PRESET Selection or SELECT Selection submenus. Such scan is hence required when the product is set up for first operation, when its location is moved or when broadcasters have changed the digital radio channel bundling/assignment. To invoke a spectrum SCAN, press the MENU button (7) three times to enable the SCAN Activation Submenu for

activation. The submenu section will start to flash; press the encoder (10) to activate. The triangle in the submenu section will turn solid once active, the Preset Station identifier (12) will show SCAN, and the player will mute. The spectrum scan will commence, and once finished, the player will change to activate PRESET Selection Submenu (19) and invoke to play the first newly assigned preset (PST-1). It shall be noted that the assignment of stations to the 10 available PRESET storage memories (PST-1....PST-10) happens in the sequence of station detection, and is not related to signal quality. Likewise, the spectrum scan will determine which stations are available in the SELECT Selection submenu (20).

■ Manual Preset Storage Procedure

Since the SCAN Activation Submenu (21) assigns stations to the PRESET storage memories (PST-1....PST-10) in the sequence of detection, it is in many cases desirable to re-assign the PRESET storage memories (PST-1....PST-10) to different stations. If specific station presets shall be assigned/overwritten with a new station choice, proceed as follows:

- Activate the SELECT Selection Submenu (20) and select a station you like.
- Press the UP button (6)**.
- Observe the Preset Station identifier (12) which will now offer a station preset for selection. Turn the encoder (10) until the required station preset is displayed. Press the encoder to confirm. Alternatively, press any of the ten station preset buttons (see section “Controls and Connections” point 10).
- The chosen station preset is now overwritten with the selected station.
- Change to the PRESET Selection Submenu (19) for direct access to the newly stored station via the encoder (10).

** Note: The UP button is disabled in the PRESET Selection Submenu.

SOURCE: Wireless Audio (LINKOUSTIC™)

■ **Display content**

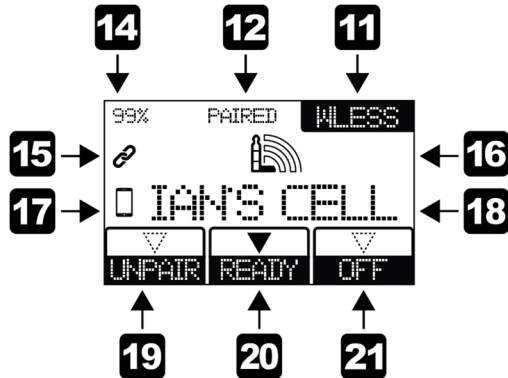

With LINKOUSTIC™ Wireless Audio as the selected source, the media player can connect to certain wireless digital audio sources, and replay content streamed through such wireless link.

Important:

- The LINKOUSTIC™ Wireless Audio link may work with certain near-field audio sources in the 2.4GHz low-energy digital wireless band. Such sources may at the same time be compatible with the Bluetooth 4.0, 4.2 or 5.0 standard, but LINKOUSTIC™ does not claim general compatibility with Bluetooth® devices, and is not a Bluetooth®-certified or listed technology. Bluetooth® is an exclusive trademark of the Bluetooth SIG.
- Due to the near-field low-energy nature of the LINKOUSTIC™ wireless link, any transmitting device must be closer than 10m from the player. Depending on the source and obstacles in a line-of-sight connection or the presence of abundant other 2.4GHz wireless sources nearby, the transmission distance may in extreme cases even be less than 5m.
- As with any wireless link, an unobstructed line of sight between source and receiver, and the absence of large metal ground planes (like e.g. metal racks) close to the receiver's antenna improve the connection quality. Always make sure the supplied antenna is securely mounted on its socket. Use an external antenna in case of mounting position in metal racks or remote positions.

- 11 Source selection indicator.** Press the SRC button (5) until “WLESS” is displayed to enable wireless audio replay, or press the “WL” button on the infrared remote control. The content identifier symbol (15) changes to a chain symbol for indicating a link to a digital audio source, and the root identifier symbol (17) changes to a mobile device symbol for indicating a mobile device’s name.
- 12 Pairing Status identifier.** Shows either “NO PAIR”, “PAIRING” or “PAIRED” depending on whether a LINKOUSTIC™-compatible digital wireless audio source is disconnected, in the connection process or connected. It shows “OFF” when the OFF Status Submenu (21) is invoked.
- 14 Player output volume.** Indicates the current setting of the player output. This can only be set via the IR remote. After a power cycle, the player will always be reset to full output volume (99%). Note that this setting refers only to the media player – if the media player is built into a host product, the host products volume may not be influenced by this.
- 15 Content Identifier Symbol.** This shows what the content identifier line (16) will contain. With Wireless Audio as the selected source this is a chain symbol to indicate a wireless link information to be contained in the content identifier line (16).
- 16 Content Identifier Line.** With Wireless Audio as the selected source, this shows the LINKOUSTIC™ logo once a compatible digital wireless audio source is connected. If no compatible source is connected, “-----” will be displayed.
- 17 Root Identifier Symbol.** This shows what the root identifier line (18) will contain. With Wireless Audio as the selected source this is a mobile device symbol to indicate a mobile device’s name to be contained in the root identified line (18).
- 18 Root Identifier Line.** With Wireless Audio as the selected source, this shows the name of the LINKOUSTIC™-compatible digital wireless audio source once being connected. If no compatible source is connected, “-----” will be displayed. Note that only device names in Latin letters are valid; device names in other letter sets will be displayed with the unified identifier “FOREIGN”.
- 19 UNPAIR Activation Submenu.** Invoking this UNPAIR activation submenu will force the player to unpair from any connected digital wireless audio source. In paired status, to execute UNPAIR activation, press the MENU button (7) once to enable the UNPAIR Activation Submenu for execution. The submenu section will start to flash; press the encoder (10) to execute. Any connected digital wireless audio source will be unpaired and disconnected

immediately. The content identifier line (16) and the root identifier line (18) will show “-----”, and the READY status submenu (20) will be activated, indicating readiness for a new pairing process. The UNPAIR activation submenu cannot be accessed if the player is unpaired already or switched OFF via the OFF status submenu (21)

20

READY Status Submenu. The READY status submenu is either activated automatically after invoking the UNPAIR activation submenu (19), or manually by pressing the MENU button (7) once when the OFF status submenu was invoked by executing the OFF status submenu (21) beforehand. Once the READY status submenu is invoked, the player can be discovered by LINKOUSTIC™-compatible digital wireless audio sources and is ready for pairing with such source. Pairing will either be initiated by:

- automatic discovery of a previously connected, known mobile device. This applies when the READY status submenu was invoked manually after OFF status submenu (21) was activated beforehand.

- manual initiation of pairing from a known or new compatible source mobile device. This applies to known mobile devices when the READY status submenu was invoked automatically by invoking the UNPAIR activation submenu (19), or to unknown mobile devices under any circumstances.

21

OFF Status Submenu. The OFF status submenu disables the LINKOUSTIC™-compatible receiver, and makes the player undiscoverable to any compatible digital wireless audio source. It can only be invoked when the READY status submenu is active. Invoking the OFF status submenu also unpairs any connected device automatically.

Notes:

- With Wireless Audio as the selected source, the UP button (6) is disabled.
- With Wireless Audio as the selected source, the Play/Pause button is disabled and the backlight LED of this button is off.

JINGLE PLAYER

■ Display content

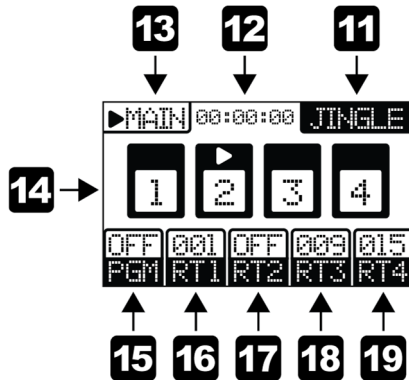

This media player contains an independent Jingle player, which exercises priority over the currently selected audio source. The jingle player features up to 4 jingles. These can be invoked manually, upon which they play once and immediately, after which the player will return to the currently selected audio source. Alternatively, the jingles can be invoked automatically, with a repeat time being set for every jingle. The relative jingle will then be invoked automatically and repeatedly per the set time schedule, and the player will return to the currently selected audio source whenever a jingle stops playing. The jingle player is a handy feature for automatically repeated announcements in hospitality or commercial environments.

To enter the jingle player screen, press the jingle button (2). The previously selected audio source will keep playing, and either a single jingle is then selected for one time play via turning the encoder (10) to the desired jingle symbol and pressing the encoder to invoke replay, or the PGM (programmed play) mode can be activated and the repetition times can be set per jingle. The jingle player screen can either be left by pressing the jingle button (2) again, or will automatically be left if a single jingle was selected for one-shot replay and such replay was executed.

Important:

- The jingle player will only work if the required jingle files are stored in a folder named “Jingles” located on the 1st hierarchy level of the USB flash memory media.

■ Up to 4 jingle files can be stored in above mentioned folder, must be in MP3 format and must be named JGL1.mp3, JGL2.mp3, JGL3.mp3 and JGL4.mp3. If less than 4 jingles are stored, the relative jingle activation symbol (14) will be disabled.

11 Source selection indicator. After entering the jingle player screen, this area will contain the word JINGLE to indicate the jingle screen being selected.

12 Remaining Jingle Play time. If a jingle is activated for replay, the remaining jingle play time is displayed here. The player will return to the selected audio source once the time is counted down to zero.

13 Jingle Source Indicator. After entering the jingle player screen, this area will display the currently playing source. In case no jingle is playing, the word MAIN is displayed to indicate that the selected audio source is playing. Once a jingle is playing, the relative jingle indicator (JGL1, JGL2, JGL3, JGL4) is displayed instead of MAIN.

14 Jingle Activation indicator. For every jingle stored in the JINGLES folder of the USB flash memory media, a jingle activation indicator with the relative jingle number will be displayed in the center area of the screen. Turning the encoder (10) will preselect a jingle for replay, indicated by the activation indicator starting to flash. Pressing the encoder will invoke replay of the preselected jingle, the activation indicator will stop flashing, and a play symbol in the shape of a small triangle will be displayed in the top of the jingle activation indicator. In addition, the jingle source indicator (13) will display the jingle under replay.

15 Programmed Mode Activation Submenu. Invoking this PROGRAMMED mode activation submenu will enable the automatically scheduled repeated replay of jingles based on timing information provided per jingle in the REPETITION activation submenus (16/17/18/19). To activate or deactivate PROGRAMMED mode, press the MENU button (7) once, the PROGRAMMED mode activation submenu symbol will start to flash, and the setting can be toggled between ON and OFF via turning the encoder (1). Press the encoder (1) to confirm your choice. If no choice is made in 5 seconds, the selection process will time out, and no changes will be applied.

16 Repetition activation submenu for Jingle 1. This submenu allows to include the relative jingle in automatic repetitive replay once the PROGRAMMED mode is set to ON (15). To make a setting, press the MENU button (7) twice, then turn the encoder (10) to either set OFF or a repetition time in minutes from 000 to 999. Confirm the choice by pressing the encoder (10). Choosing the OFF setting

means the relative jingle will be excluded from automatic repetitive replay even if PROGRAMMED mode is set to ON. Note that settings can only be made if the relative jingle file exists in the JINGLES folder of the USB flash memory media; if no relative file exists, the settings will be OFF by default. Further note that time settings made for every jingle will remain saved when the PROGRAMMED mode (15) is set to OFF, and will hence be recalled when the PROGRAMMED mode is next time set to ON.

17 **Repetition activation submenu for Jingle 2.** This submenu works in the same manner as the Jingle 1 REPETITION activation submenu.

18 **Repetition activation submenu for Jingle 3.** This submenu works in the same manner as the Jingle 1 REPETITION activation submenu.

19 **Repetition activation submenu for Jingle 4.** This submenu works in the same manner as the Jingle 1 REPETITION activation submenu.

■ Scheduling Considerations

To understand scheduling well, the following facts are important:

- If repetition times for jingles are set with the PROGRAMMED mode ON, then repetition times will count from the moment the jingle is assigned to a repetition time. This means start times may be shifted as there is no common zero time.
- If repetition times for jingles are set with the PROGRAMMED mode OFF, then repetition times will count from the moment the PROGRAMMED mode is switched ON, meaning all start times will refer to common zero time.
- If two jingles are scheduled to start at the same time, the lower jingle number will be given a preference.
- Once another jingle is given a preference, the non-preferred jingle will be skipped and NOT played.

As an example, if both jingle 1 and jingle 2 are both set to repetition every 1 minute while PROGRAMMED mode is OFF and then switched ON, the two jingles would start their schedule at the same zero time, so jingle 2 would never be played as jingle 1 would have preference over Jingle 2 since they would both be due for start at the same time. Likewise, if Jingle 2 is set to 2 minutes, it will still not be played, as every time jingle 2 will be

due for replay, Jingle 1 will also be due for replay and will have preference.

Short schedule times hence are only suitable for single jingle repetitions. Alternate repetitions of jingle 1 and jingle are e.g. possible by setting jingle1 to a repeat time of 2 minutes and jingle 2 to 3 minutes. This will lead to the following:

Minute 2: Jingle 1 playing

Minute 3: Jingle 2 playing

Minute 2: Jingle 1 playing

Minute 6: Jingle 1 playing (as preference over jingle 2)

Minute 8: Jingle 1 playing

Minute 9: Jingle 2 playing

Minute 10: Jingle 1 playing

Minute 12: Jingle 1 playing (as preference over jingle 2)

Minute 15: Jingle 2 playing

Etc...

Jingle 3 could e.g. be schedule in to play every 7 minutes.

■ Source Considerations

Every jingle replay needs to be understood as a source change towards MP3 replay with the relative jingle being the file played. Hence returning to the selected program source will work best if this program source is also the USB player; in this case playing a jingle is just like playing another song. If the selected program source is the FM radio receiver or the DAB+ receiver, it may take short time for the tuner to lock back into the chosen station after a jingle is played; if the selected program source is the LINKOUSTIC™ Wireless Audio receiver, it may take slightly more time to re-pair with the previously paired mobile device. For the best use experience, it is hence suggested to mainly use the jingle player with the USB player, the FM tuner or the DAB+ receiver as the selected program source.

Technical Data

| | |
|---------------------|---|
| Sources |USB-PGM, USB-JGL, FM, DAB+, Linkoustic |
| USB file types: |MP3, WAV, FLAC, APE |
| MPEG |1/2/2.5L3-128/160/192/224/256/320/VBR |
| Storage Media |FAT12/16/32/ExFAT, 64GB max |
| Linkoustic™ freq. |2.4GHz |
| DAB+ frequency..... | Band III 174.928-239.200 MHz |
| AC IN |115V/230~ 50/60Hz, max 12W |
| Dimensions WxDxH |482.6x180x44mm |
| Weight |2.3 kg |

Warranty

This product is guaranteed to be free of defects in material and workmanship at the time of purchase. Send-in warranty repair is granted for a period determined by

- A period of at least 6 months (from the date of purchase), or the minimum period required by law in the territory of sale, whichever is longer.
- A period of no longer (from the date of purchase) than the specified average lifetime of a component by the component's manufacturer.

INTUSONIC

INTUSONIC is a brand of
Unitec Industries Limited

www.intusonic.com

