

INTUWORX DLA26

2-IN-6 Stereo Splitter

RevB

Welcome

Thank you for choosing INTUSONIC for your sound system. To make sure that this product meets your expectations and provides long-term, reliable performance, please read and follow this instruction manual carefully.

Manual language

- UK** This user manual is written in English. For other languages, please use an auto-translation service of your choice.
- FR** Ce guide est écrit en anglais. Pour les autres langues, veuillez utiliser un service de traduction automatique de votre choix.
- DE** Diese Anleitung ist in Englisch verfasst. Für andere Sprachen verwenden Sie bitte einen automatischen Übersetzungsdienst Ihrer Wahl.
- ES** Este manual está escrito en Inglés. Para otros idiomas, utilice un servicio de traducción automática de su elección.
- PT** Este manual está escrito em Inglês. Para outros idiomas, use um serviço de tradução automática de sua escolha.
- IT** Questo manuale è scritto in inglese. Per altre lingue, utilizza un servizio di traduzione automatica a tua scelta.

Important safety instructions

- Read these instructions and all markings on the product. Keep these instructions.
- Heed all warnings and instructions, both in this manual and on the product.
- Clean only with a dry cloth. Unplug the unit or its power adaptor/charger from AC supply before cleaning.
- Do not use this product near water and avoid any exposure to water.
- Before connecting this product to any AC supply (if any), make sure to check whether the AC mains voltage and frequency match the indication on the product and its packaging.
- Only connect this product or its power adaptor/charger to an AC supply (if any) with sufficient power handling, protective earth connection, ground-fault (earth-fault) protection and overload protection.

- Disconnect the product or its power adaptor/charger from the AC supply (if any) during thunderstorms or longer periods of being unused.
- Make sure any heat sink or other cooling surface, or any air convection slot, is exposed sufficiently to free air circulation and is not blocked.
- Do not operate this product in environmental temperatures exceeding 35 degrees Celsius and/or 85% relative humidity.
- Position the product in a safe and stable place for operation, out of reach of unauthorized persons.
- Make sure any cable connections to and from the product are neither subject to potentially destructive mechanical impact nor present any risk of stumbling or other accident risk to people.
- Audio equipment may generate sound pressure levels sufficient to cause permanent hearing damage to persons. Always start up at low volume settings and avoid prolonged exposure to sound pressure levels exceeding 90dB.
- Do not open this product for service purposes. There are no user-serviceable parts inside.
- Warranty will be void in any case of unauthorized service by the user or other not authorized persons.
- Take any precaution required by local law, applicable regulations or good business practice to avoid injury of people or material damage by use of this product.

Symbols used in this manual



DANGER! Safety hazard. Risk of injury or death.



ATTENTION! Read manual before installation and operation.



WARNING! Hazardous voltage. Risk of severe or fatal electric shock.



WARNING! Fire hazard.

Health Advice

This unit may produce and absorb electromagnetic radiation. The strength of radiation and the sensitivity for disturbing interference matches the CE and FCC requirements. A corresponding sign is printed on the backside of the unit. Any change or modification may affect the behavior of the unit

concerning electromagnetic radiation, with the CE and FCC requirements eventually not to be met any more. The manufacturer takes no responsibility in this case.

Functional Advice (only for powered products)

This unit is immune to the presence of electromagnetic disturbances – both conducted and radiated - up to a certain level. Under peak conditions, the unit is classified to show a “class C” performance criteria and may encounter temporary degradation or loss of function which may need manual help to recover. In such case, switch the unit off and back on to recover.

Environmental Advice

This unit is built to conform to the ROHS-2 standard according to directive 2011/65/EU and the WEEE directive 2012/19/EU of the European Parliament and of the Council of the European Union. Under these regulations, the product shall not be discarded into regular garbage at the end of its life, but shall be returned to authorized recycling stations.

Battery Advice (only for battery-powered products)

- Some products may contain a battery. Refer to the further chapters of this manual to determine whether this product contains a battery, and whether this is removable and/or rechargeable.
- Where applicable, adhere to the relative regulations in aviation transport.
- If the battery is rechargeable, the battery might not be fully charged or partly discharged at the time of purchase. Recharge before use. Only use recommended or included chargers with appropriate voltage/current rating.



WARNING! Fire hazard. Batteries might heat up during charging. Only charge in a place with sufficient air convection.

Wireless Advice

- Some products may contain a wireless transmitter, receiver or transceiver. Refer to the further chapters of this manual to determine whether this product contains a wireless function, and in which frequency this operates.

- Make sure the frequency of operation does not require a specific license in the territory you operate the product in. If it does, obtain such license prior to any operation.
- Certain wireless technologies are designed for short distance operation. The actual distance will depend on how jammed the frequency band is at the location of use. In adverse cases, operational distances might be as low as 5m. In normal circumstances, 10m can be assumed. Test the operational distance prior to relying on the wireless functionality in a specific application.

Unpacking

Please check that the box contains the following items:

- 1 pc. main unit
- 1 pc. AC cord set
- 1 pc. instruction manual

If any part is missing, please contact your dealer immediately for replacement.



WARNING! After unpacking, and before plugging the AC cord in the wall outlet, check whether the AC mains voltage and frequency is the same as this product is specified for (see rear panel of product). Whenever the specified voltage or your AC plug should not match the local conditions, do NOT plug the AC cord into the wall outlet and contact your dealer immediately.

AC Mains Voltage Setting

If the AC mains voltage of your power outlet and the setting of the AC supply voltage on your unit do not match, contact your dealer, contractor or a qualified service workshop to change the setting of the AC voltage selector. The AC voltage selector switch is located on the side panel of the unit, close to the AC inlet.

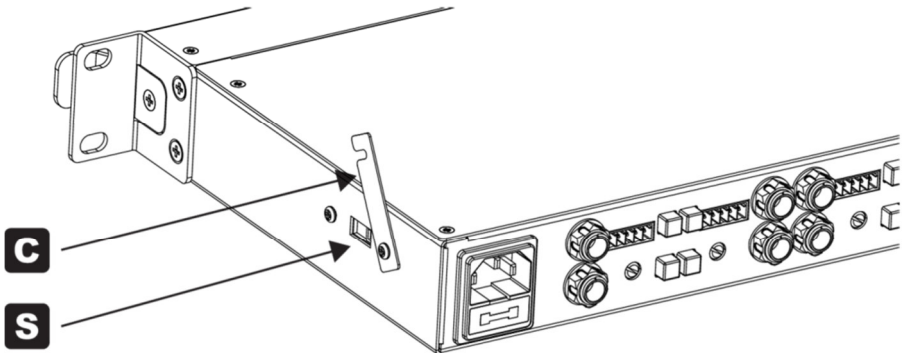

For a qualified technician to change the AC voltage setting, the AC cord shall be detached, the security cover (C) shall be flipped up, and the Voltage selector switch (S) shall be set to the new position. Afterwards, the security cover (C) shall be set back into a protective position to avoid tampering with the switch.

Rack/Cabinet Mounting

This product comes pre-assembled with 19" rack ears and handles. Depending on the location of installation and use, it might be commendable to remove either only the handles, or both the rack ears and handles. To do so, remove the screws at the side panel of the units as shown: To remove the handle (H), remove the single center screw out of the group of 3 screws at the front side of the metal cabinet. Pull the handles out to the front. To also remove the rack ears (E), remove the remaining two screws and then remove the rack ear.

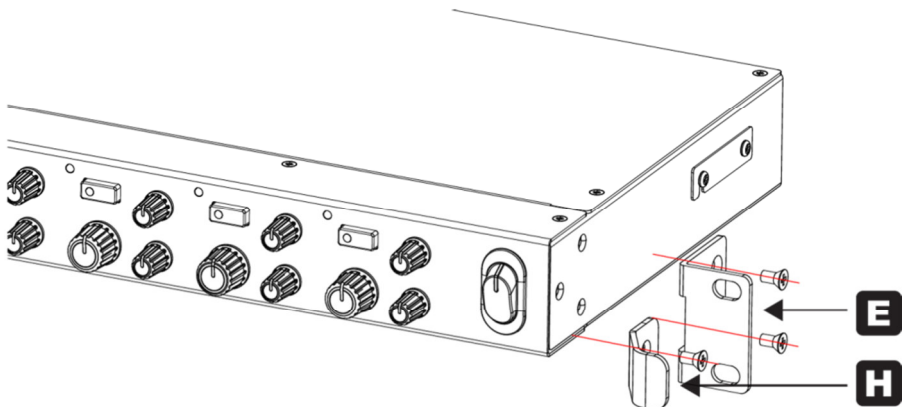

About this product

The DLA26 is a 2-in/6-Out stereo signal splitter, aka distribution amplifier. It can feed up to 6 individual output from 2 inputs, and thus allows to build large multi-zone systems. For extended flexibility, all outputs can be switched to mono and have their own switchable 100Hz high pass filter, making it easy to integrate auxiliary mono zones which utilize smaller speakers. Apart from signal distribution, the DLA26 can also integrate basic emergency and evacuation functionality into a sound system.

Configuration

The DLA26 can be configured to meet certain operational requirements by setting internal jumpers. As a factory default, all jumpers are set to the ON position.



WARNING! Any action which requires opening the product shall only be expedited by qualified service technicians. Remove the AC cord before opening the product. Be aware that the warranty may be void unless you are an appointed Intusonic installer, contractor or technical service provider.

To change the jumper settings, unscrew the top lid from the product and remove it. The jumpers are located on the rear PCB assembly as per following illustration and functional description:

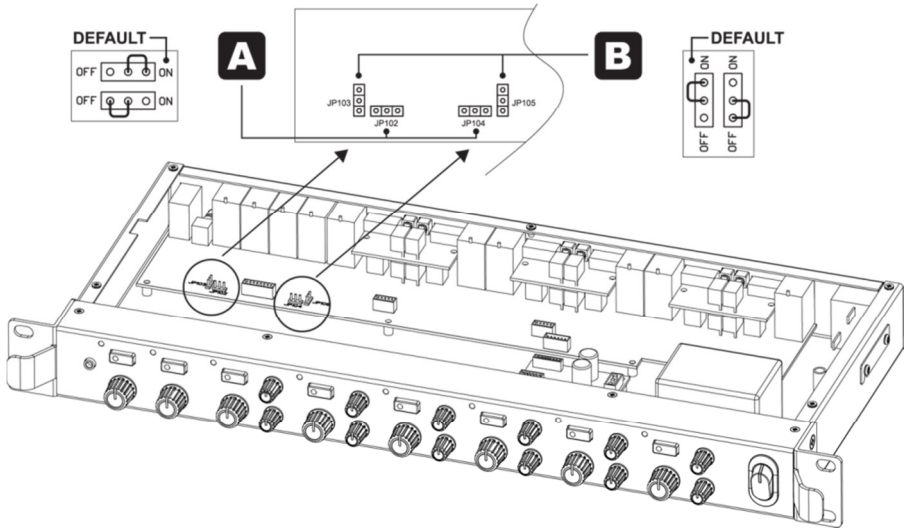

A **Emergency Mute.** Jumpers JP102 (for Signal-A output) and JP104 (for Signal-B Output) decide whether the loop-through outputs of the feeding signals A and B carry forward the muting of the signal when a signal become present at emergency input (12). This setting can be useful if the input signal is supposed to be forwarded to a different subsystem, but that subsystem has its own emergency features. Mostly this jumper will be set in conjunction with the emergency signal jumpers (see following point B).

B **Emergency Signal.** Jumpers JP103 (for Signal-A output) and JP105 (for Signal-B Output) decide whether the loop-through outputs of the feeding signals A and B will carry forward the emergency signal when such signal becomes present at emergency input (12). This setting can be useful if the input signal is supposed to be forwarded to a different subsystem, but that subsystem has its own emergency features. Mostly this jumper will be set in conjunction with the emergency mute jumpers (see previous point A).

Note that theses jumper do only influence the feedthrough outputs of the input signals A and B. They have no influence on the outputs 1-6 whatsoever.

Controls and Connections

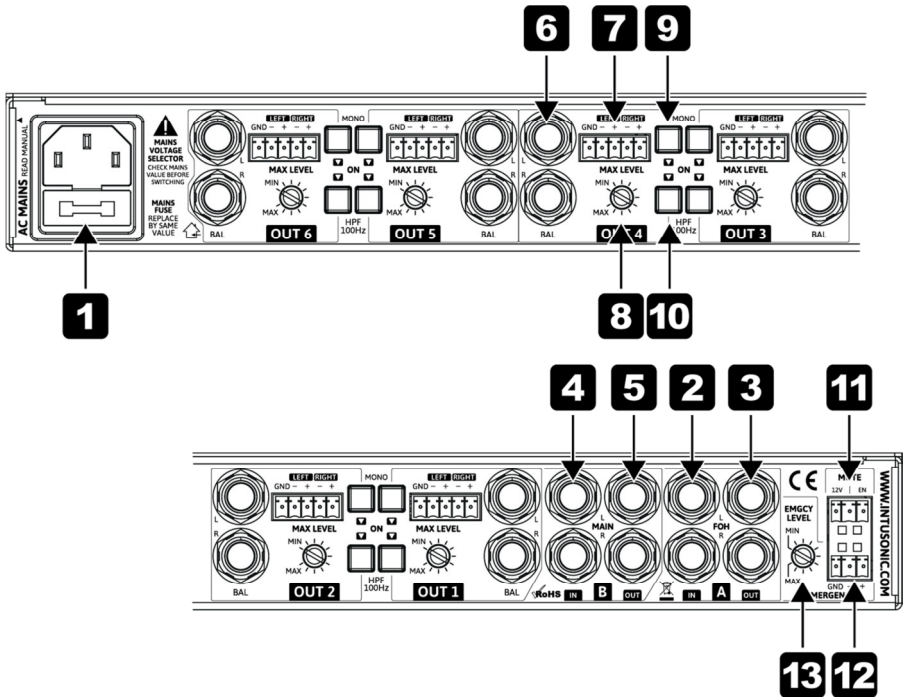

- 1 AC inlet and fuse holder.** Use the supplied AC cord to connect the unit to AC mains. Make sure voltage and frequency stated and set on the unit comply with your local AC supply. The fuse can be accessed by the small drawer at the AC inlet. To change the fuse, unplug the AC cord first, pull out the fuse drawer and replace the fuse ONLY with a fuse of SAME voltage and rating. If the fuse blows again after replacement, hand over the unit to qualified service personnel.
- 2 Stereo Signal “A” input (FOH).** This is a pair of 1/4” balanced TRS jacks. The signal fed into this input will be replicated at the stereo signal “A” output (3). The signal is available in the outputs 1-6 as the “source A” signal, but will be replaced by the signal inserted in the front-panel 3-5mm TRS socket once a jack is inserted into this socket (16).
- 3 Stereo Signal “A” output (FOH).** This is a pair of 1/4” balanced TRS jacks. For the purpose of forwarding the input signal to more

DLA26 units or other subsystems, the signal fed into the stereo signal “A” input (2) is replicated here. It can be decided by internal jumper settings whether emergency features are carried forward on this output (see chapter “configuration” for details).

- 4 Stereo Signal “B” input (Main).** This is a pair of 1/4” balanced TRS jacks. The signal fed into this input will be replicated at the stereo signal “B” output (5). The signal is available in the outputs 1-6 as the “source B” signal.
- 5 Stereo Signal “B” output (FOH).** This is a pair of 1/4” balanced TRS jacks. For the purpose of forwarding the input signal to more DLA26 units or other subsystems, the signal fed into the stereo signal “B” input (4) is replicated here. It can be decided by internal jumper settings whether emergency features are carried forward on this output (see chapter “configuration” for details).
- 6 Stereo signal output (outputs 1-6, visualized at output 4).** This is a pair of 1/4” balanced TRS jacks. This output will carry the signal selected with the input selector switch (23) in the relative outputs control section on the front panel. It will be influenced by the other controls in the relative outputs control section on the front panel and the settings made on the relative outputs section on the rear panel.
- 7 Stereo signal output (outputs 1-6, visualized at output 4).** This is a terminal block output carrying the same signal as the balanced TRS output (6).
- 8 Maximum level setting (outputs 1-6, visualized at output 4).** This control allows to limit the maximum level at relative stereo signal outputs (6)/(7) in order to match the connected sound system. Adjustments made on this control will not be displayed by the output peak indicator (24). Adjustments shall be made with a small screw driver. Note that the total angle is 300 degrees; do not apply excessive force with the screw driver. audible instead.
- 9 Output mono switch.** This switch sets the relative outputs (6)/(7) to mono operation if the connected sound system(s) requires to do so. The mono signal will be available on both the left and right channel of outputs (6)/(7).
- 10 Output high pass filter (HPF).** This switch activates a 100Hz HPF at the relative output (6)/(7). If the output feeds smaller speaker or ceiling speakers with open back, this may be a recommendable setting.
- 11 Music Mute input.** This is a terminal block input which allows to remotely mute all stereo outputs (6)/(7) by simply shortening the contacts. Note this will affect ALL outputs.
- 12 Emergency input.** This is an auto-sensing, balanced terminal block input which allows the connection to an emergency evacuation

system. Once a signal is present on this input, the stereo output signals (6)/(7) will all be muted and the emergency message/signal from this input will become audible instead, at the volume set by the emergency level control (13).

13 Emergency volume control. This control allows to set the level with which the signal fed into the emergency input (12) will be replayed at the stereo outputs (6)/(7).

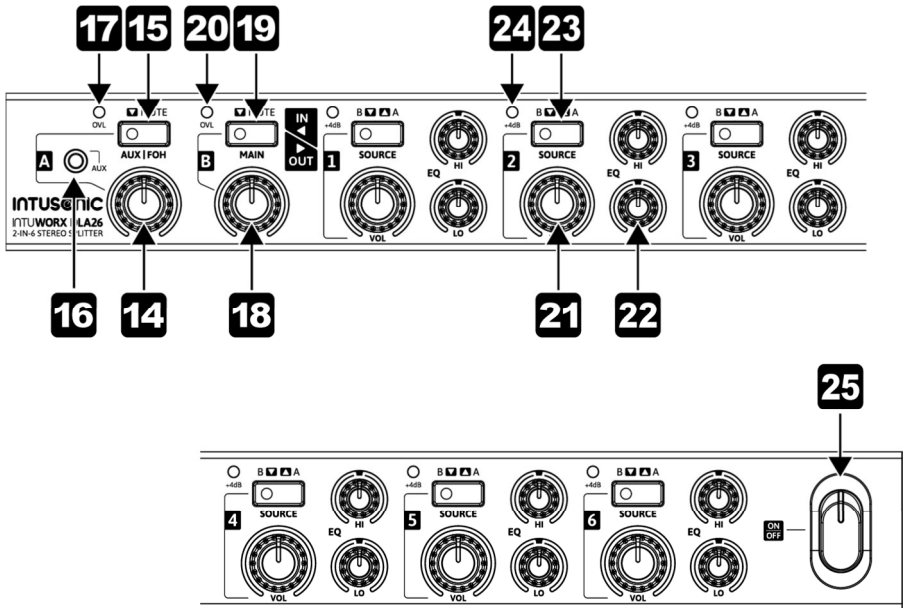

14 Input volume adjustment for Input “A”. This control allows to adjust the input “A” level to the source level. Make sure that the input level overload indicator (17) only flashes occasionally, to avoid excessive input levels.











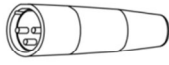

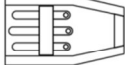
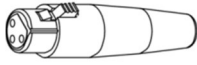
15 Input mute switch for Input “A”. Press this switch to mute the input “A”. The indicator LED in the switch cap will be lit when the input is muted.

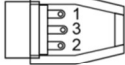
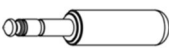
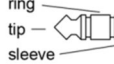
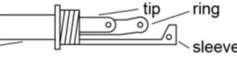
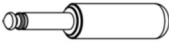
16 AUX signal input connector for input “A”. This is a 3.5mm Mini-TRS unbalanced stereo socket which allows the connection of sources like MP3 players etc. without removing the unit from its mounting position. Once a plug is inserted, the rear-side connected input signal “A” is disabled and the source connected to this 3.5mm Mini-TRS is the active signal for input “A”.

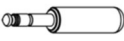
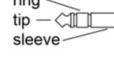
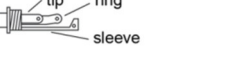
- 17** **Level Overload Indicator for Input “A”.** This LED indicates that the safe input level to Input “A” is exceeded. Reduce the setting of the input volume control (14).
- 18** **Input volume adjustment for Input “B”.** This control allows to adjust the input “B” level to the source level. Make sure that the input level overload indicator (20) only flashes occasionally, to avoid excessive input levels.
- 19** **Input mute switch for Input “B”.** Press this switch to mute the input “B”. The indicator LED in the switch cap will be lit when the input is muted.
- 20** **Level Overload Indicator for Input “B”.** This LED indicates that the safe input level to Input “B” is exceeded. Reduce the setting of the input volume control (18).
- 21** **Output volume control for outputs 1/2/3/4/5/6.** Allows the adjustment of the volume of the relative output. Note the final level is also influenced by the rear-side maximum level control (8).
- 22** **Equalizer for outputs 1/2/3/4/5/6.** Allows the adjustment of the tonal balance for the respective output in two frequency bands with an adjustment range of ± 12 dB.
- 23** **Source selector switch for outputs 1/2/3/4/5/6.** Allows the selection of Input “A” or “B” as the source for the relative output. The pressed position selects input “B”, and the indicator LED in the switch cap will be lit.
- 24** **Output peak Indicator for outputs 1/2/3/4/5/6.** This LED indicates that the output level exceeds +4dBu. Reduce the level with the output volume control (21).
- 25** **Power switch.** Switches the unit on and off. Make sure to switch the unit off when not in use. The ON position is indicated by a backlight.

Cabling

This product may use all or a selection of the below connector types, for which the pin assignment must comply with the following specification. Always make sure to use good connectors and cables to ensure proper operation. Balanced connections are to be preferred over unbalanced connections where applicable and feasible. Avoid unbalanced connections exceeding 2m of cable length.

	Structure		Balanced connection	Unbalanced connection
XLR male		 plug side  cable side	red = 2 black = 3 shield = 1	red = 2 shield = 1+3
XLR female		 plug side  cable side	red = 2 black = 3 shield = 1	red = 2 shield = 1+3
6.35mm TRS-stereo		 ring tip sleeve  ring tip sleeve	red = tip black = ring shield = sleeve	red = tip shield = sleeve+ring
6.35mm TRS-mono		 tip sleeve  tip sleeve	red = tip black = sleeve shield = uncon.	red = tip shield = sleeve
3.5mm TRS-stereo		 ring tip sleeve  ring tip sleeve	red = tip black = ring shield = sleeve	red = tip shield = sleeve+ring
RCA		 tip sleeve  tip sleeve	red = tip black = sleeve shield = uncon.	red = tip shield = sleeve
Terminal Plug		 → 	red = 1 black = 2 shield = 3	red = 1 shield = 2+3

CABLE Types

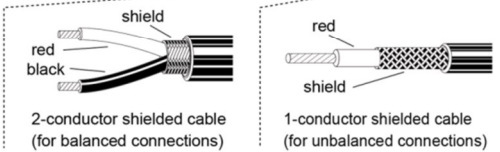

Block diagram

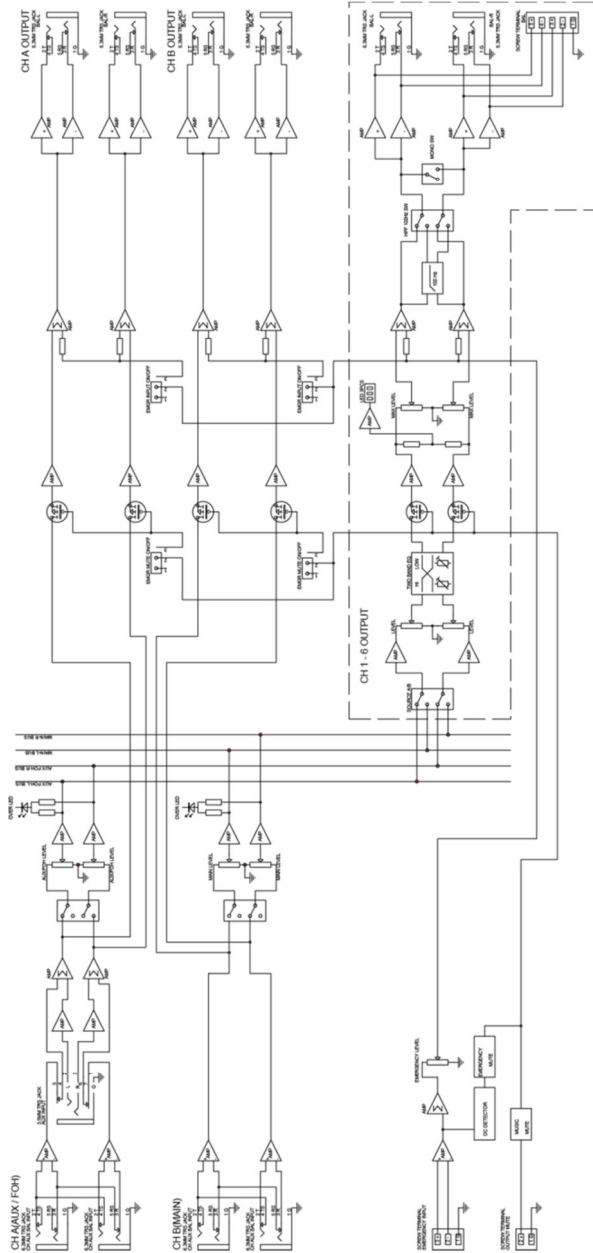

■ Technical Data

Inputs A/B, Input Impedance12.5kΩ
Inputs A/B, max. input level17.8dBu
Inputs A/B, crosstalk-75dBu
Out 1/2/3/4/5/6, residual noise-86dBu
Out 1/2/3/4/5/6, THD0.016%
Out 1/2/3/4/5/6, LR crosstalk-73dBu
Main Out, FQ response20H-20kHz (+0.5dB)
AC IN115/230V~, 50/60Hz, 12W
Dimensions WxDxH482.6x210x44 mm
Weight2.9 kg

■ Warranty

This product is guaranteed to be free of defects in material and workmanship at the time of purchase. Send-in warranty repair is granted for a period determined by

- A period of at least 6 months (from the date of purchase), or the minimum period required by law in the territory of sale, whichever is longer.
- A period of no longer (from the date of purchase) than the specified average lifetime of a component by the component's manufacturer.

UK Declaration of Conformity

The manufacturer

Adelto Industries, Unit 4 Britannia Business Park, Comet Way,
Southend-on-Sea, Essex, SS2 6GE, United Kingdom

Declares at his sole responsibility that the equipment

INTUSONIC DLA26

is in conformity with the relevant legislation of the United Kingdom as
listed below, with the following applicable standards:

UK SI 2016 No. 1091 Electromagnetic Compatibility Regulations 2016:
BS EN IEC 55035:2017

UK SI 2016 No. 1101 The Electrical Equipment (Safety) Regulations 2016:
BS EN IEC 62368-1

UK SI 2012 No. 3032 Restriction of the Use of Certain Hazardous Sub-
stances in Electrical and Electronic Equipment Regulations 2012 (RoHS2)
BS EN IEC 63000:2018

And is marked as follows:



Southend-on-Sea, 19th March 2021

A handwritten signature in black ink, appearing to read 'J. Johnson'.

Authorized Signature

EC Declaration of Conformity

The manufacturer

Adelto Industries, Unit 4 Britannia Business Park, Comet Way,
Southend-on-Sea, Essex, SS2 6GE, United Kingdom

Declares at his sole responsibility that the equipment

INTUSONIC DLA26

is in conformity with the following directives/standards/regulations:

EMC Directive 2014/30/EU

EN55035:2017

LVD Directive 2014/35/EU

EN62368-1

ROHS2 Directive 2011/65/EU & 2015/863/EU

EN63000:2018

And is marked as follows:



Southend-on-Sea, 19th March 2021

A handwritten signature in black ink, appearing to read 'J. Johnson', written in a cursive style.

Authorized Signature

INTUSONIC

INTUSONIC is a brand of
Universal Technical Industries Co. Ltd.

Concept, Design & Distribution by

Adelto Industries Limited

Unit 4 Britannia Business Park

Comet Way, Southend-on-Sea

Essex, SS2 6GE, United Kingdom

www.adelto.com / sales@adelto.com